

LO[®]

LO[®] Pure[®]

Product information sheet



Product range

LO

LO Pure, the sitting/standing desk for offices, offers prices comparable to foreign-made desks – combined with proven quality made in Switzerland. LO Pure is all about reduction to pure function while still conforming to all relevant office furniture standards. Minimum order volume: 50 units.

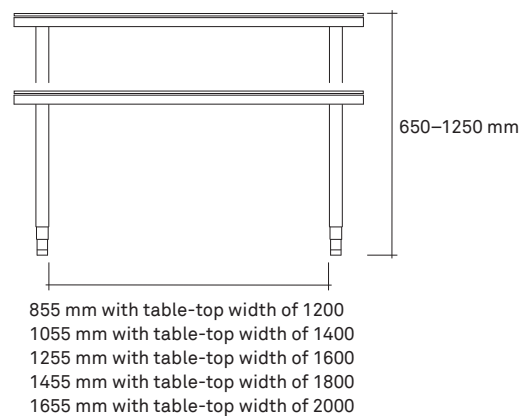

Details



Pure and minimalist, but with details that impress: control element, pen tray, CPU holder, levelling function and cable conduit. A variety of earthed plug boxes provide a simple power solution and reduce electrosmog by over 65 %.

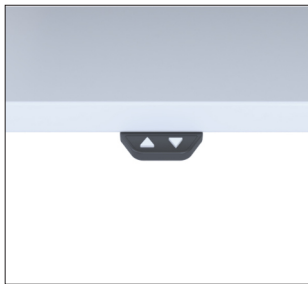

Up/down control



Up/down control with display



Control element with memory



Swivelling cable conduit



CPU holder

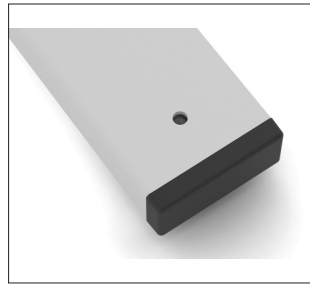

Levelling of legs



Cable sleeve

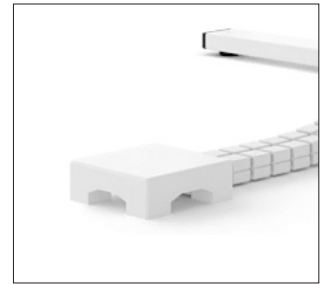

Cable termination

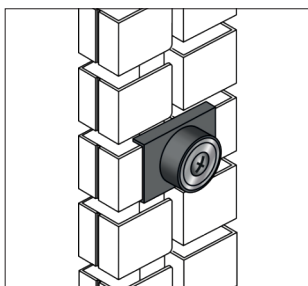

Magnetic holder on cable sleeve

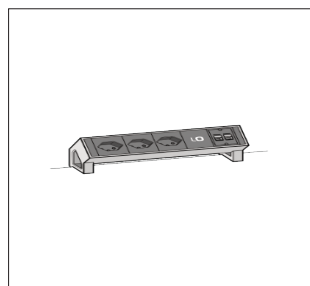

Desk 2 Power Strip

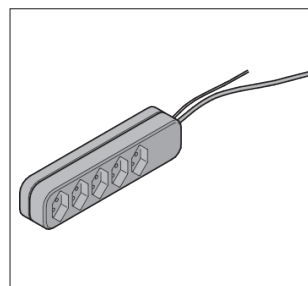

Plug box

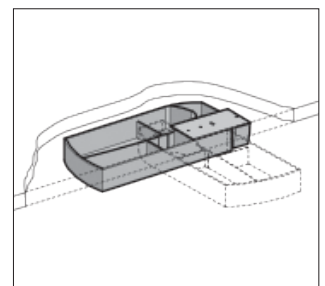

Pencil tray traversable

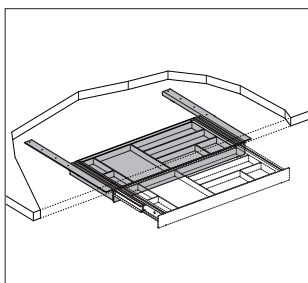

Pencil tray traversable

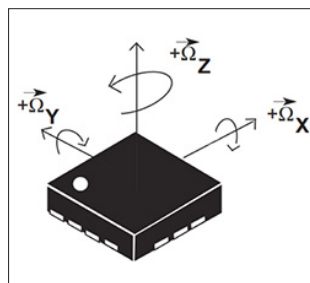

Collision protection «plus»

Organisation

No concentration without peace and quiet. No order without a system. Choice of three noise-dampening privacy screens with matching organisational elements – for concentration, order and individuality.



Privacy screen "formfleece"



Privacy screen "screen"

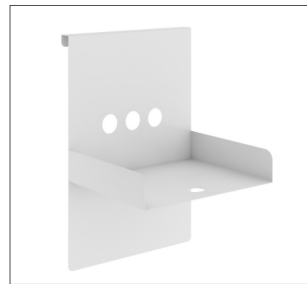

A4 horizontal tray

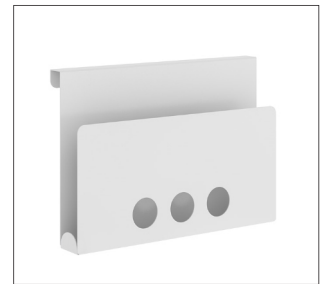

A4 vertical tray

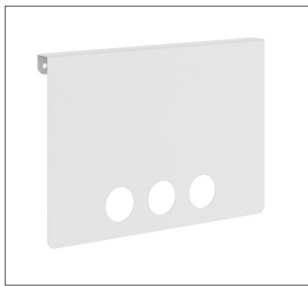

Magnetic panel, small /
Magnetic panel, large

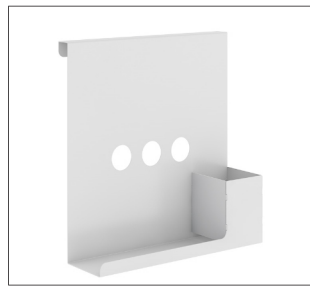

Pen tray

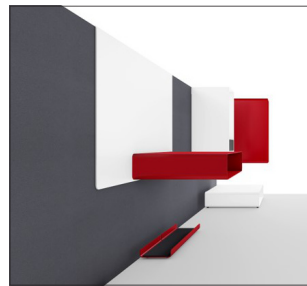

Privacy screen "function"

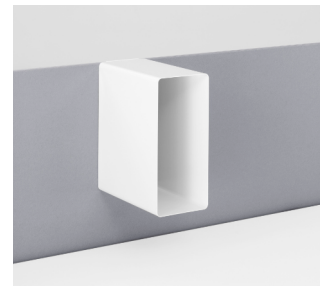

Panel box folder



Vertical panel box with drawer

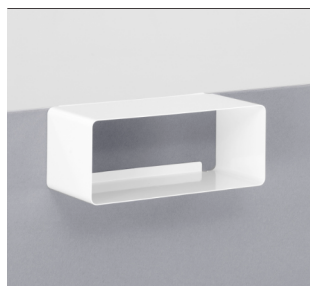

Horizontal panel box

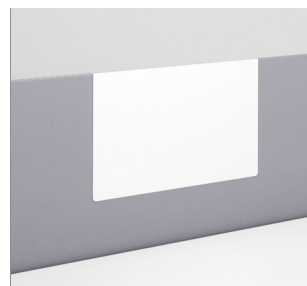

Magnetic panel

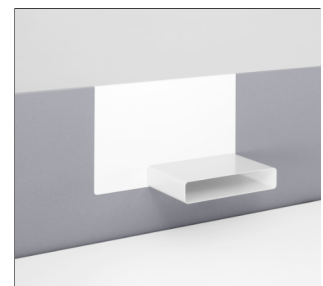

Magnetic panel with
A4 compartment

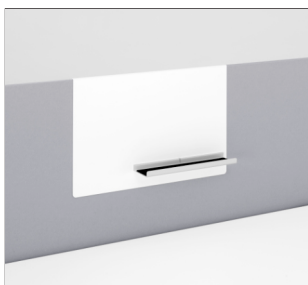

Magnetic panel with tray



Stackable A4 desk tray



Desktop box with T13 plug socket

Warranty

LOG Produktions AG guarantees Lista Office LO products for five years from delivery ex works. A five-year warranty period also applies to the electric motor systems used in the product ranges LO Extend, LO Choice and LO Pure. All other bought-in parts used in our own products (such as textiles, glass components, etc.) and/or electronic components (such as software, plug boxes, etc.) are guaranteed for two years from the date of delivery. Replaces all previous price lists. We reserve the right to make changes to the prices, designs and dimensions of products. LOG Produktions AG is certified in accordance with ISO 9001 and ISO 14001.

You can find care and maintenance instructions for your product on our home page. You can find information on how to assemble and use your product in the user manual.



Version

Version 1.0, September 2017 (date created)
Version 1.1, February 2018
Version 1.2, October 2018 (LO Colors update)
Version 2.0, September 2019 (Product range expansion)
Version 2.1, December 2019 (Collision protection «plus»)
Version 2.2, April 2020 (Product range expansion)
Version 2.3, February 2021 (Certificate Update)
Version 2.4, January 2024 (Removal of the colours)

Lista Office LO
LOG Produktions AG
Alfred Lienhard Strasse 2
9113 Degersheim
Switzerland

Telephone +41 71 372 52 52
Hotline 0800 633 642
info@lista-office.com

www.lista-office.com