

LO[®]

LO[®] D11[®]

Product information sheet



Product range

LO

Round, square, rectangular, oval or curved, big or small – LO D11 conference tables come in the perfect form for any meeting. The laser-welded steel subframe, simultaneously elegant and sturdy, creates meeting and discussion zones that are as strong as they are stylish.

Alternative versions and extra large sizes available on request.

Conference table, round

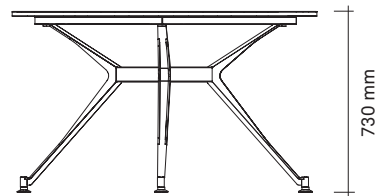
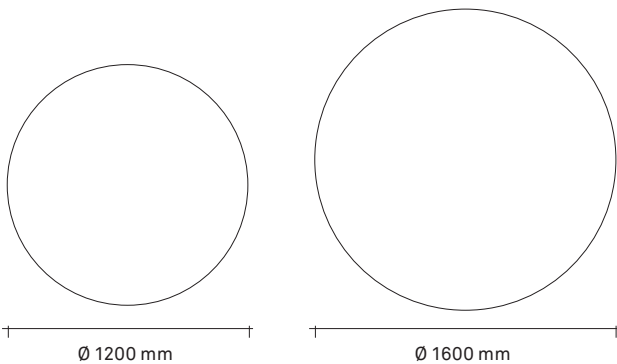

Conference table, square

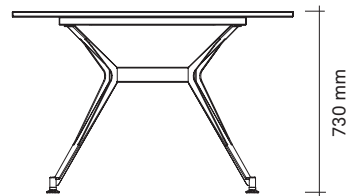
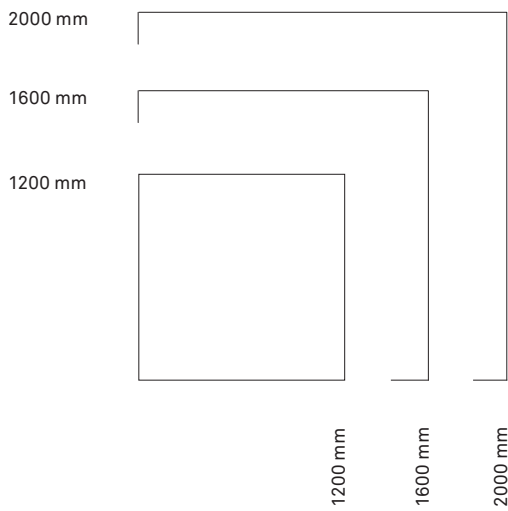

Conference table, rectangular

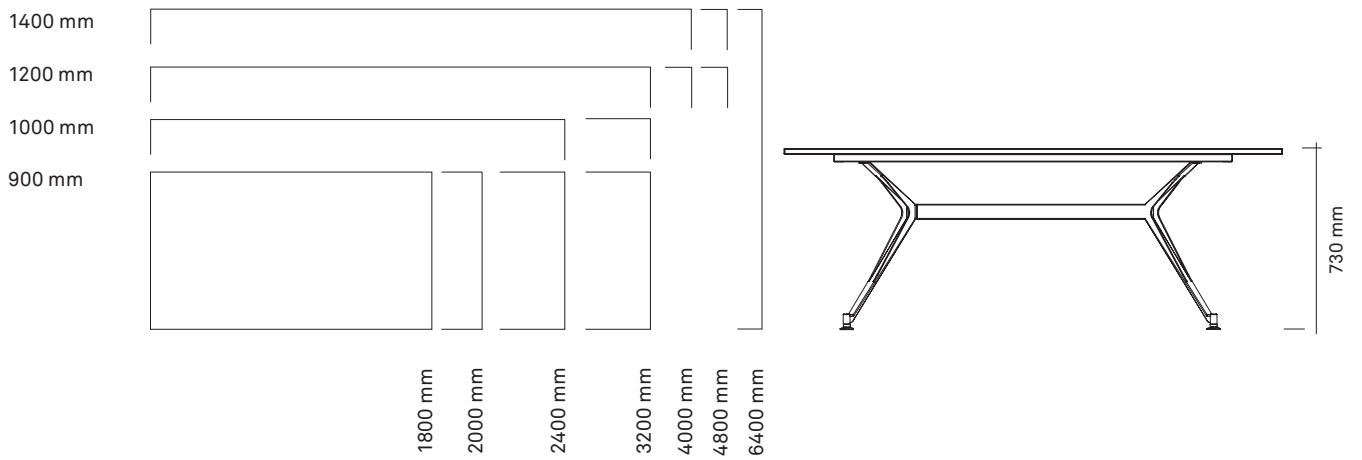

Conference table, long sides curved

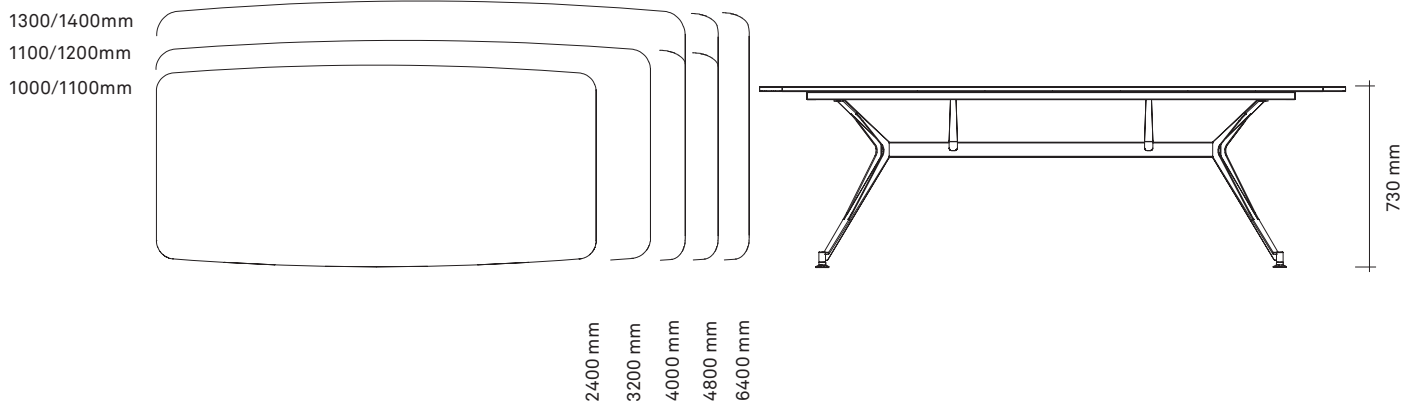

Conference table, long and short sides curved

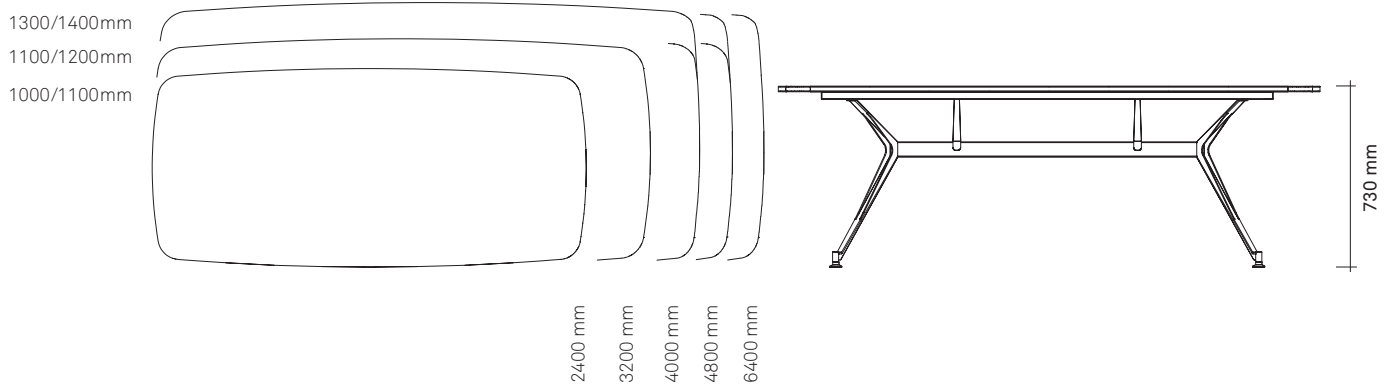

Conference table, oval

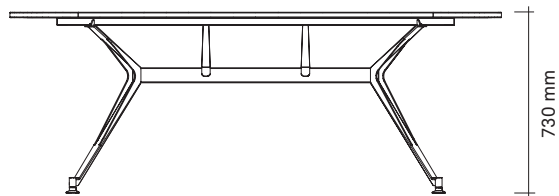
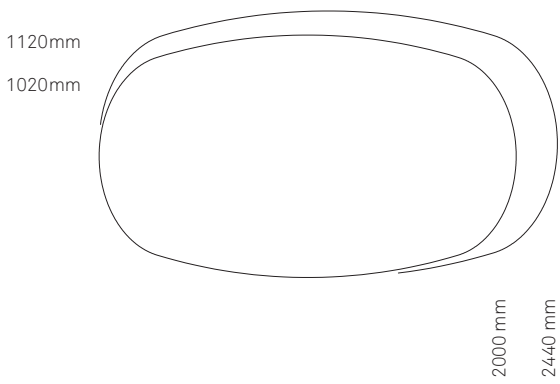
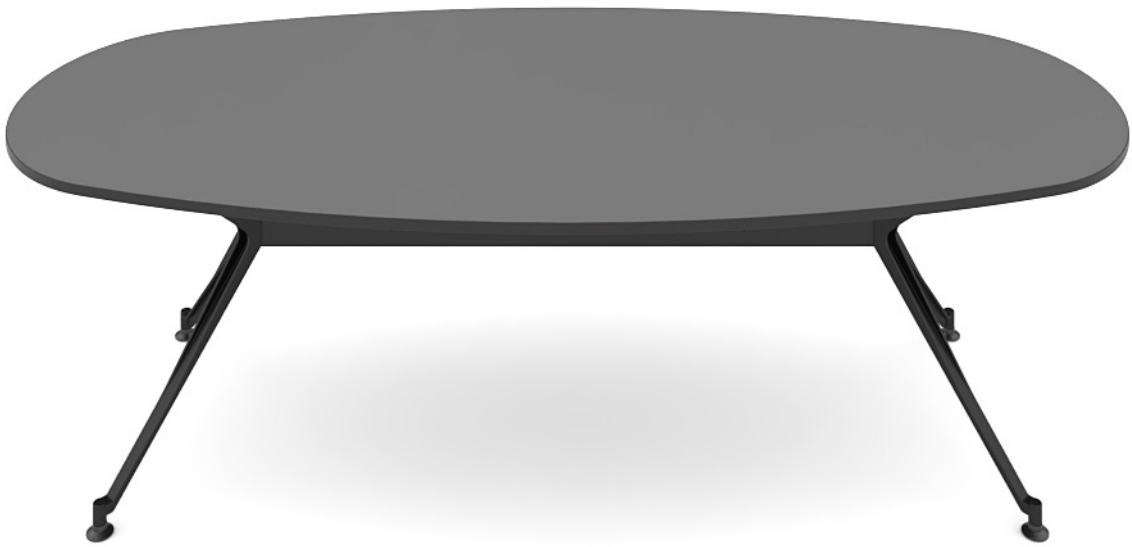

Details

LO

As well as the attractive design, it also impresses with useful details: LO D11 features leg caps that allow the table to glide almost weightlessly over carpets, parquet floors and concrete. On uneven floors, it can be levelled by up to 20 mm; the levelling function is integrated into the design and accessible from above. The intelligently designed power supply keeps the table clear both on top and underneath.



Levelling

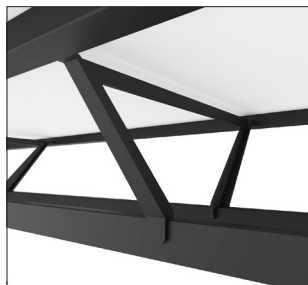

middle traverse



Cable conduit (low mounting)



Cable conduit (high mounting)



Cable tidy



Cable guide

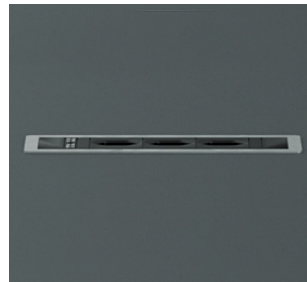

Electrical system Power Frame

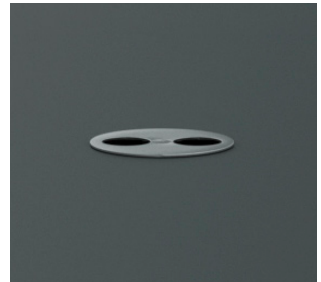

Electrical system Twist

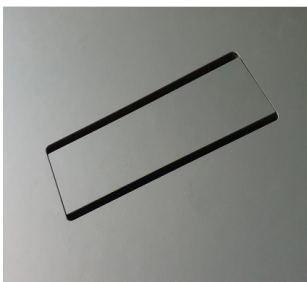

Magnetic plate

LO Colors colour concept

A focused use of colours in the office adds a touch of design flair. It bolsters corporate identity, and increases the team's motivation and productivity. LO D11 are available in a range of colours and supplementary materials such as (solid) wood, linoleum or synthetic resin. This gives the office visual flair and opens up scope for individuality.

Steel



«Standard» powder coating (S1)



deep matt black
NCS S 9000-N

Panels



Synthetic resin (K1)

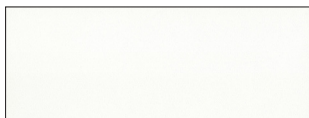

pure white
NCS S 0500-N

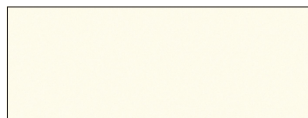

crystal white
NCS S 0502-Y

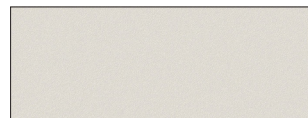

light grey
NCS S 1500-N

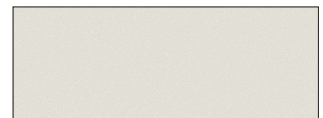

pebble grey
NCS S 1502-Y

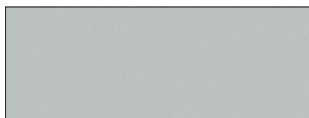

misty grey
NCS S 2301-B90G



dusty grey
NCS S 5000-N

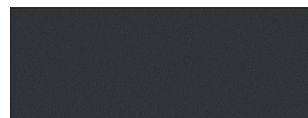

graphite black
NCS S 8500-N



maple decor

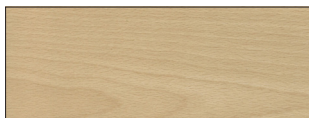

beech decor



oak decor



walnut decor

Panels



Solid-core panels (H1)



pure white
NCS S 0500-N

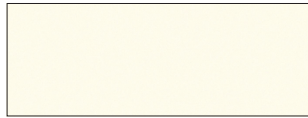

cristal white
NCS S 0502-Y

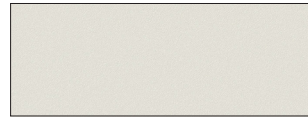

pebble grey
NCS S 1502-Y



dusty grey
NCS S 5000-N

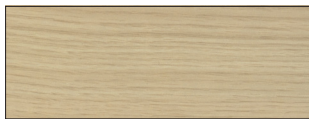

natural oak decor



Fenix (H1)

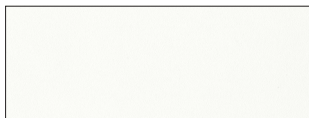

pure white
NCS S 0500-N

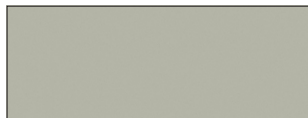

stone grey
NCS S 3005-Y50R

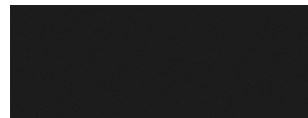

black
NCS S 8500-N



Linoleum (H2)

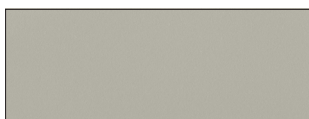

pebble
NCS S 3502-Y

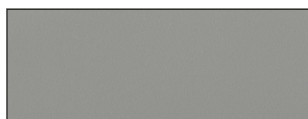

ash
NCS S 5502-G



pewter
NCS S 7005-B20G



mauve
NCS S 7005-Y80R



charcoal
NCS S 8502-B



nero
NCS S 9000-N

Panels



Wood panels (H1, H2)



natural maple



natural beech



stained beech



natur oak



cremona oak



middle brown oak thermo



dark brown oak thermo



black oak



natural walnut simple



natural walnut

Warranty

LOG Produktions AG guarantees Lista Office LO products for five years from delivery ex works. A five-year warranty period also applies to the electric motor systems used in the product ranges LO Extend, LO Choice and LO Pure. All other bought-in parts used in our own products (such as textiles, glass components, etc.) and/or electronic components (such as software, plug boxes, etc.) are guaranteed for two years from the date of delivery. Replaces all previous price lists. We reserve the right to make changes to the prices, designs and dimensions of products. LOG Produktions AG is certified in accordance with ISO 9001 and ISO 14001.

You can find care and maintenance instructions for your product on our home page. You can find information on how to assemble and use your product in the user manual.



Version

Version 1.0, May 2017 (date created)

Version 1.1, February 2018

Version 1.2, October 2018 (LO Colors update)

Version 1.3, August 2022 (Product range expansion)

Lista Office LO
LOG Produktions AG
Alfred Lienhard Strasse 2
9113 Degersheim
Switzerland

Telephone +41 71 372 52 52
Hotline 0800 633 642
info@lista-office.com

www.lista-office.com